

PROFESSIONAL CHEST HEATED IRONERS

I
RANGE

I 25

I 30

250MM

290MM



FEATURES

- Attractive design
- Standard finger guard protection
- When unattended, the device shuts off automatically
- Reduced number of mechanical and moving parts for a lower maintenance cost
- Homogeneous ironing pressure to ensure top ironing quality
- PID controlled temperature regulation offering better temperature distribution and reduced energy consumption
- Long-life heating elements
- Anodised extruded aluminium profile avoiding temperature drop and ensuring top ironing quality
- All vital components are easily accessible
- Start/stop pedal
- Backside of the basin is insulated with 25mm ceramic wool - no energy waste

OPTIONS

- Frequency inverter enabling variable ironing speed
- Fan exhaust removing humid air from the ironer (I25-140, I30-160, I30-200)



COMPACT
DESIGN



EASY
OPERATION



OPTIMIZED
OUTPUT

TYPE		I25-100	I25-100V*	I25-120	I25-120V*	I25-140	I25-140V*	I25-140AV**	I30-160	I30-160AV**	I30-200AV**
ROLLER DIMENSIONS											
Length	mm	1000	1000	1200	1200	1400	1400	1400	1600	1600	2000
Diameter	mm	250	250	250	250	250	250	250	290	290	290
CAPACITY											
Relative Humidity	kg/h	30	30	35	35	40	40	40	32-50	32-50	52-79
Type of Heating	%	10-15	10-15	10-15	10-15	10-15	10-15	20-25	20-25	20-25	40-45
SPEED											
	m/min	3,9	2-4	3,9	2-4	3,9	2-4	2-4	3,9	2-4	2-4
VOLTAGE/Hz/Phase Circuit Breaker											
230/50/1		25 A	25 A	32 A	32 A	32 A	32 A	40 A	N/A	N/A	N/A
230/50/3		16 A	16 A	16 A	16 A	25 A	25 A	25 A	40 A	40 A	50 A
230/60/1		25 A	25 A	32 A	32 A	32 A	32 A	40 A	N/A	N/A	N/A
230/60/3		16 A	16 A	16 A	16 A	25 A	25 A	25 A	40 A	40 A	50 A
400/50/3		10 A	10 A	10 A	10 A	16 A	16 A	16 A	25 A	25 A	32 A
400/60/3		10 A	10 A	10 A	10 A	16 A	16 A	16 A	25 A	25 A	32 A
440/60/3		10 A	10 A	10 A	10 A	16 A	16 A	16 A	25 A	25 A	32 A
480/60/3		10 A	10 A	10 A	10 A	16 A	16 A	16 A	16 A	16 A	25 A
Heating Power	kW	5	5	6	6	7	7	8,4	13,2	13,2	16,8
Motor Rated Input	kW	0,18	0,18	0,18	0,18	0,18	0,18	0,215	0,48	0,67	0,67
Total Electric Supply	kW	5,18	5,18	6,18	6,18	7,18	7,18	8,615	13,68	13,87	17,47
Exhaust Diameter	mm	N/A	N/A	N/A	N/A	N/A	N/A	55	60	60	60
DIMENSIONS											
Height	mm	1005	1005	1005	1005	1005	1005	1005	1100	1100	1100
Width	mm	1400	1400	1600	1600	1800	1800	1800	2200	2200	2600
Depth	mm	420	420	420	420	420	420	420	500	500	500
Net weight	kg	110	110	118	118	135	135	135	262	262	294
TRANSPORT DATA											
Height	mm	1150	1150	1150	1150	1150	1150	1150	1260	1260	1260
Width	mm	1480	1480	1680	1680	1880	1880	1880	2280	2280	2690
Depth	mm	500	500	500	500	500	500	500	590	590	590
Gross weight	kg	119	119	130	130	154	154	154	300	300	350

*Option V = Variable Speed & Adjustable Temperature

**Option AV = Variable Speed, Adjustable Temperature, & Suction Fan

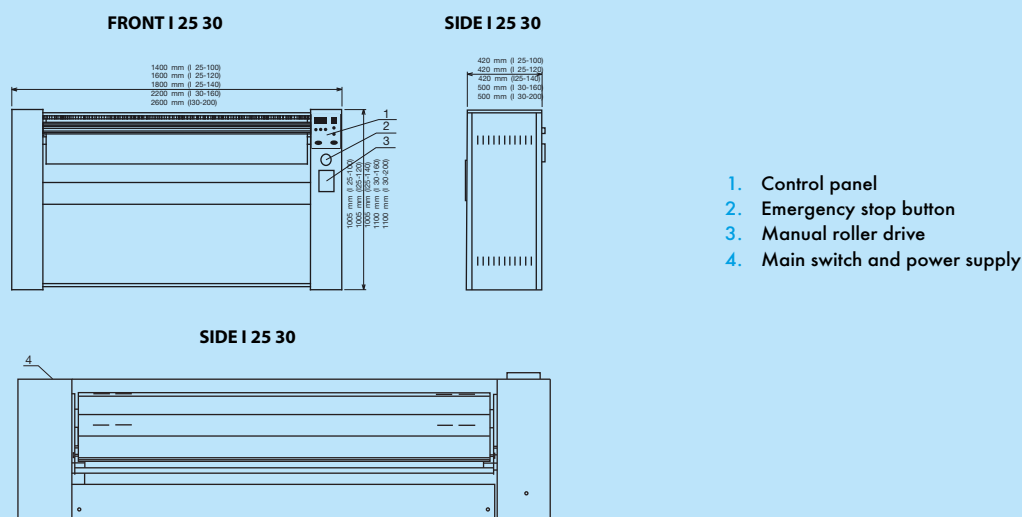

The company preserves the right to change the machines and the specification in this leaflet at any time, without prior notice. Details and photographs are only for information and never binding.

www.primuslaundry.com

Primus by Alliance Laundry Systems



12-2017